

The logo for HydroMet, featuring a white diagonal slash followed by the text "HydroMet" in a bold, white, sans-serif font.

/ HydroMet

User Manual

HailSens IoT

The KISTERS logo, consisting of a white stylized 'K' symbol followed by the word "KISTERS" in a bold, white, sans-serif font. Below the logo is the tagline "Empowering decisions of tomorrow" in a smaller, white, sans-serif font.

KISTERS
Empowering decisions of tomorrow

Table of Contents

I	Disclaimer	3
II	Glossary + Abbreviations	4
III	Scope of Delivery	5
IV	Safety Instructions	6
V	Specific Safety Instructions	7
Part I	Introduction	8
Part II	Installation	9
2.1	HailSens IoT: Mechanical Dimensions	9
2.2	Pole Mounting	9
2.3	Selecting a suitable installation site	10
2.4	Electrical Bonding (Earth)	10
2.5	External Cable Connection	10
2.5.1	Connecting the Ethernet cable	11
2.6	For Wireless Data Communication: Insert SIM Card	12
Part III	Configuration	13
3.1	LTE-M Wireless Data Transmission (MOBILE COMMS)	15
3.2	Ethernet Data Transmission (STATIC COMMS)	15
Part IV	Operation	16
4.1	HailSens IoT: Electronics	16
4.2	HailSens IoT: Power Supply	16
4.3	RESTful API/JSON	16
Part V	Maintenance	17
5.1	Overall Visual Check	17
5.2	General Cleaning	17
5.2.1	Do's and Don'ts	17
Part VI	Troubleshooting	18
Part VII	Repair	19
Part VIII	Technical Data	20
Part IX	Obligations of the Operator and Disposal	21

I Disclaimer

The software programs described in this document and the information contained in this document are confidential and proprietary products of HyQuest Solutions or its licensors. HyQuest Solutions waives copyright for licensed software users to print out parts of the documentation in hard copy for their own use only.

This documentation may not be transferred, disclosed, or otherwise provided to third parties. In duplicating any part of this document, the recipient agrees to make every reasonable effort to prevent the unauthorized use and distribution of the proprietary information.

No parts of this work may be reproduced in any form or by any means - graphic, electronic, or mechanical, including photocopying, recording, taping, or information storage and retrieval systems - without the written permission of the publisher.

HyQuest Solutions makes no warranty of any kind with regard to this material including, but not limited to, the implied warranties or merchantability and fitness for a particular purpose.

HyQuest Solutions shall not be liable for any incidental, indirect, special or consequential damages whatsoever (including but not limited to lost profits) arising out of or related to this documentation, the information contained in it or from the use of programs and source code that may accompany it, even if HyQuest Solutions has been advised of the possibility of such damages.

Any errors found in any HyQuest Solutions product should be reported to HyQuest Solutions where every effort will be made to quickly resolve the problem.

This document is public.



II Glossary + Abbreviations

ACRONYM	Description
A	SI unit symbol of the “ampere”, a unit of current intensity
Ah	SI unit symbol of the “ampere hour”, a unit of electrical charge (electric current multiplied by time)
ASCII	American Standard Code for Information Interchange
Comms	techno-babble for data transmission/communication
Mx	ISO metric screw thread sizes, specifying the nominal outer diameter of the screw, where x is the diameter in mm
mm	SI unit symbol of the unit of length “millimeter” in the metric system
Nm	SI unit symbol of the unit of torque (or “moment”)
RS485	standard defining the electrical characteristics of drivers and receivers for use in serial communications systems using balanced signals over differential line; RS485 does not define a protocol but an electrical interface
RS232	standard defining the electrical characteristics of drivers and receivers for use in serial communications systems; valid signals are either in the range of +3 to +15 volts or the range -3 to -15 volts with respect to the "Common Ground" (GND) pin; consequently, the range between -3 to +3 volts is not a valid RS-232 level; RS232 does not define a protocol but an electrical interface
SI	International System of Units
USB	Universal serial Bus, industry standard defining cables, connectors and communication protocols for serial data transmission between computers and devices
VDC	Volts of Direct Current
W	SI unit symbol of the “watt”, a unit of power



III Scope of Delivery

- Hail Sensor IoT pre-mounted unit
- Power connection cable M12 4-pin
- Pole mounting bracket
- FAT document

IV Safety Instructions

- Read the user manual including all operating instructions prior to installing, connecting and powering up the KISTERS HailSens IoT. The manual provides information on how to operate the product. The manual is intended to be used by qualified personnel, i.e. personnel that have been adequately trained, are sufficiently familiar with installation, mounting, wiring, powering up and operation of the product.
 - Keep the user manual on hand for later reference!
 - If you encounter problems understanding the information in the manual (or part thereof), please consult the manufacturer or its appointed reseller for further support.
 - KISTERS HailSens IoT is intended to be used in hydrometeorological or environmental monitoring applications.
 - Before starting to work, you have to check the functioning and integrity of the system.
 - Check for visible defects on the HailSens IoT, this may or may not include any or all of the following mounting facilities, connectors and connections, mechanical parts, internal or external communication devices, power supplies or power supply lines, etc.
 - If defects are found that jeopardize the operational safety, work must be stopped. This is true for defects found before starting to work as well as for defects found while working.
 - Do not use the KISTERS HailSens IoT in areas where there is a danger of explosion.
 - The present user manual specifies environmental/climatic operating conditions as well as mechanical and electrical conditions. Installation, wiring, powering up and operating the KISTERS HailSens IoT must strictly comply with these specifications.
 - Perform maintenance only when tools or machinery are not in operation.
 - If guards are removed to perform maintenance, replace them immediately after servicing.
 - Never make any electrical or mechanical diagnostics, inspections or repairs under any circumstances. Return the product to the manufacturer's named repair centre. You can find information on how to return items for repair in the relevant section of the KISTERS website.
-  Disposal instructions: After taking the KISTERS HailSens IoT out of service, it must be disposed of in compliance with local waste and environmental regulations. The KISTERS HailSens IoT is never to be disposed in household waste!
-  Inputs and outputs of the device are protected against electric discharges and surges (so-called ESD). Do not touch any part of the electronic components! If you need to touch any part, please discharge yourself, i.e. by touching grounded metal parts.

V Specific Safety Instructions

- As an electrically powered system, HailSens IoT requires to be grounded. This is required to provide a reliable means to safely conduct the voltages imposed by lighting, line surges, or un-intentional contact with high voltage lines or equipment to ground.
-   HailSens IoT is equipped with a bird-guard exposing metal spikes. Wear gloves while installing the sensor.

1 Introduction

HailSens IoT is an advanced sensor system for monitoring hail events in real-time. The detection of hail impacts relies on impact energy measurement. HailSens IoT provides accurate, reliable results both quickly and automatically.

The present document is the User's Manual for HailSens IoT.

HailSens IoT is the perfect choice if you wish to sample individual hail events either for study purposes or to determine the damage potential of a hail event. HailSens IoT is a modern IT-based monitoring device with local data storage and advanced communication facilities. It is operated on 12 VDC. The sensor records individual hail impacts. It measures the kinetic energy of each impact.

Apart from initial setup and periodic maintenance (once a year right before the hail season), HailSens IoT does not require any particular interaction or attendance. The device will only transmit data telegrams when hail impacts are detected. In addition, a heartbeat telegram is transmitted every 6 hours. Data telegrams contain data relevant to an individual hail pellet impact and additional sensor status information.

In typical setups, HailSens IoT will transmit data to the (optional) KISTERS datasphere, an online data management tool providing functionality ranging from data reception and storage to visualisation and alarming. Please contact your sales person for details!



Figure 1 - HailSens IoT

2 Installation

1. Unpack the HailSens IoT from its transport container
2. Check completeness of the delivery
3. Mount the HailSens IoT
4. For wireless communication: insert data SIM
5. Power up the HailSens IoT
6. The sensor starts working

2.1 HailSens IoT: Mechanical Dimensions

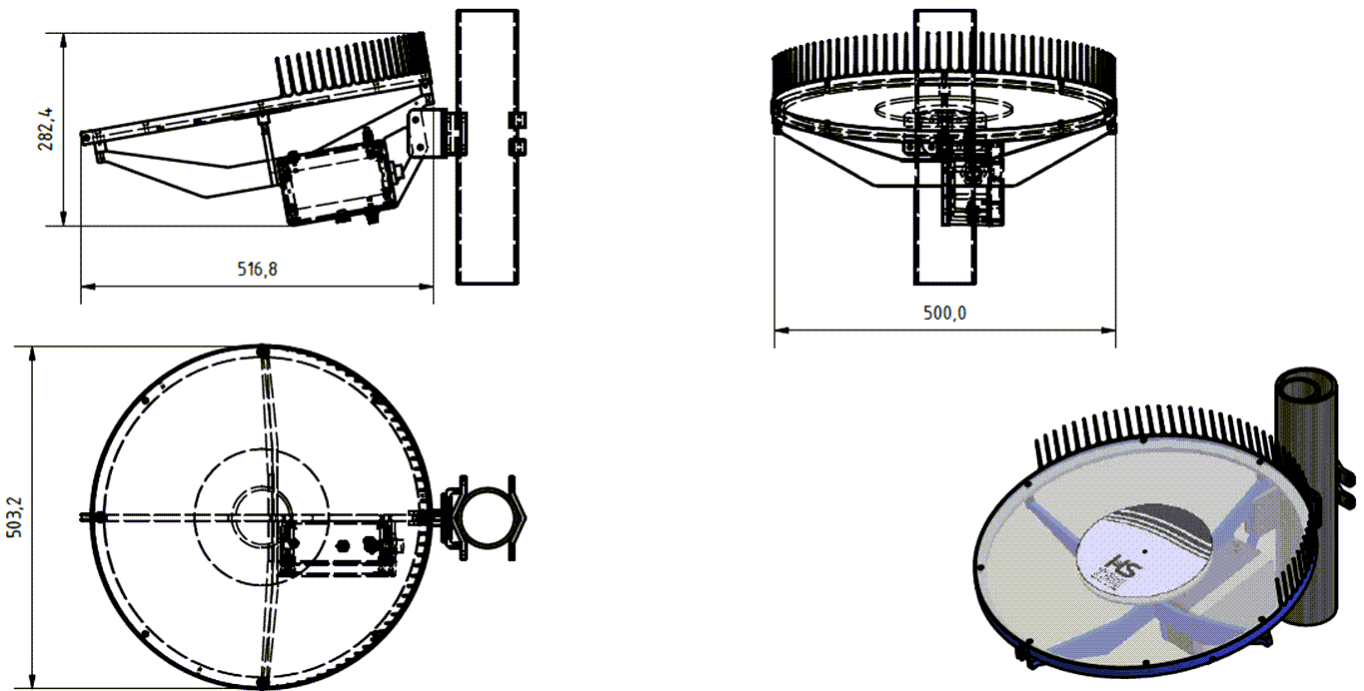

Figure 2 - Dimensions in mm

2.2 Pole Mounting

HailSens IoT is delivered with a pole mount bracket and bolts and washers.



Figure 3 - HailSens IoT Pole Mount Bracket with Bolts and Washers

The pole mount bracket is designed for poles of a diameter between 1.5" and 4".



Figure 4 – Pole-Mount Bracket mounted on a Pole

2.3 Selecting a suitable installation site

When the Hail Sensor is installed, the following should be considered:

- Avoid obstruction to sensor plate (i.e. clear areas are required no trees, close high-rise, etc.)
- Avoid nearby power line & communication towers (i.e. anything that could attract lightning & surges)
- Avoid high wind areas

Recommendations:

- Pole mounting: recommended mounting height is roughly 1 m above the ground.
- In hilly terrain or in mountainous areas, the sensor plate should be at 2 m above the ground. This is to avoid cluttering in snow during the winter period.

2.4 Electrical Bonding (Earth)

The electronics box is equipped with an M6 earth stud. The position of the Earth stud is shown in the following figure.

The Sensor is designed for 12 VDC operation. Electrical bonding provides protection from potentially dangerous potential differences in the metallic parts. In addition, influence on the transducers are minimized, as potential electrostatic charges will be diverted to earth. Caution: lightning strikes may still result in irreversible damage to the electronics components.



Figure 5 – Electrical Bonding (Earth): position of the Earth Stud on the Electronic Box

2.5 External Cable Connection

Connectors are provided to connect external cables.

- M12 4-pin: power supply
- SMA: antenna
- Cat6 plug: Ethernet cable connection

The position of the connectors is illustrated in the following figure:



Figure 6 – Connectors on top and right side of the Electronics Box

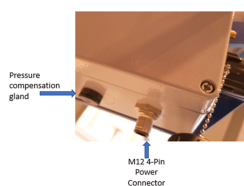

Figure 7 – Connectors at the bottom of the Electronics Box

2.5.1 Connecting the Ethernet cable

HailSens IoT is equipped with a specific RJ45 connector. To ensure waterproof protection, the outer RJ45 connector must be sealed with the supplied cap or a connected cable with a waterproof cable gland. Two caps are delivered:

The round closing cap is used as long as no cable is fitted. Waterproof and weatherproof CAT6 RJ45 jack with RJ45 jack at the back (RJ45 pass through).



The conical cap is used with a cable. Threaded coupling for waterproof and dustproof mounting on CAT6 RJ45 jack. Please use CAT6 cable with 7-9 mm OD for dustproof and waterproof connection.

Simply slide this conical cap onto the open end(s) of the CAT6 cable. Crimp an RJ45 connector to the open cable end. Connect the RJ45 plug into the waterproof CAT6 RJ45 jack and screw this waterproof protector to the waterproof CAT6 RJ45 jack.

2.6 For Wireless Data Communication: Insert SIM Card

A SIM card must be inserted into the SIM Card Slot of the integrated data logger/data modem unit.

Unscrew the lid (4 screws) and remove it. Insert the SIM.

Make sure data services are activated for the SIM Card.

3 Configuration

The HailSens IoT can be user-configured. Start the browser and enter the following URL:

`http://192.168.2.2`

The configuration dialogue opens in your browser.

IoTα-F30X Custom Solutions
Edge M2M Extender

HailSens Series II Configuration

GENERAL/REST

SensorIdent:

Service URL:

User:

Pass:

HailSens Calibration

Calparam 1:

Calparam 2:

Threshold:

Calibration Mode:

MOBILE COMMS

SIM.Pin	<input type="text" value="XXXX"/>	<input type="button" value="Save"/>
APN	<input type="text" value="wt.tnce.net"/>	<input type="button" value="Save"/>
APNuser	<input type="text"/>	<input type="button" value="Save"/>
APNpass	<input type="text"/>	<input type="button" value="Save"/>
Authentication	<input type="text" value="None"/>	<input type="button" value="Save"/>
Connection Retries	<input type="text" value="5"/>	<input type="button" value="Save"/>
Connection Error Timeout	<input type="text" value="1000"/>	<input type="button" value="Save"/>

STATIC COMMS

IP Address	<input type="text" value="192.168.13.31"/>	<input type="button" value="Save"/>
NetMask	<input type="text" value="255.255.255.0"/>	<input type="button" value="Save"/>
Network	<input type="text" value="STATIC"/>	<input type="button" value="Save"/>
Default Gateway	<input type="text"/>	<input type="button" value="Save"/>
Timeserver	<input type="text" value="time.nasa.gov"/>	<input type="button" value="Save"/>
Static Network Interface Mode	<input checked="" type="checkbox"/>	<input type="button" value="Save"/>

SYSTEMINFO

Modem: MoTa-F30X

Home Network Operator:

Current RAT: Not available

Signal: No signal strength

Distribution: Poky (Yocto Project Reference Distro) 2.2.3

FSN: VU011505181110

Host system: Linux fx30 3.18.44

SERVICES

You are coming from [::ffff:192.168.2.2]

[running] SensorBoardReaderext

[running] RestWriter

[running] GateKeeper

Figure 8 – HailSens IoT Configuration Dialogue

The Network settings only apply to the Ethernet port and do not affect the USB-based network connection.

The parameters that can be edited by the user are listed and briefly explained in the following table.

After applying changes in the NETWORK section, a reboot of the device is required to activate the settings. To perform the reboot, please disconnect the device from the power-source for at least 5 seconds.

Section	Parameter	Comment
GENERAL/REST	SensorIdent	Sensor UUID
	Service URL	<code>http://tsoupload.kisters.de/HailsensUpload/rest</code>
	User	Username (authentication)
	Pass	Password (authentication)
HailSens Calibration	Calparam 1 - 3	calibration settings; individual setting for each sensor
	Calibration Mode	Check to enter Calibration Mode
MOBILE COMMS	SIM-Pin	Pin of the inserted SIM card
	APN	APN for inserted SIM
	APNuser	APN User (if required)
	APNpass	APN Pass (if required)
	Authentication	Authentication Method
	Connection Retries	Connection Retries
	Connection Error Timeout	Connection Error Timeout
STATIC COMMS	IP-Adress	Fixed IP-Adress or address obtained by DHCP
	NetMask	Netmask for IP-Adress
	Network	IP-Mode (DHCP/STATIC)
	Default Gateway	Default Gateway
	Static Network Interface Mode	Check if cable-bound, uncheck for mobile comms

Table 1 - HailSens IoT Configuration: Settings List

The network-mode (mobile or Ethernet) can be switched by checking the according box "Static network interface active" in the "Static Comms" section.

The currently selected mode can be indicated by the red background of the according section (example in the figure above: Static comms is active).

3.1 LTE-M Wireless Data Transmission (MOBILE COMMS)

To use the integrated LTE-M modem for data transmission, a data SIM must be installed.

Initial settings must be made in order to use the HailSens IoT with the data SIM card installed. Use a SIM card that is either exclusively for data communication or where data communication tariffs have been activated. Phone calls using data communication require an exclusive app.

APN setup is required to connect to the Internet. APN is an access point for connecting to the Internet. It should be configured according to the contract plan you have with your network operator. If APN setup has not yet been performed on the communication device, be sure to perform APN registration.

For details see [figure 131](#) in topic [Configuration 131](#), section: MOBILE COMMS.

Note: In some regions and depending on availability of data modems, the sensor can be equipped with a standard 4G LT Cat1 modem. Contact your provider to make sure to obtain a compatible SIM card.

3.2 Ethernet Data Transmission (STATIC COMMS)

The factory setting is set to DHCP which allows to access the unit after connecting to the network providing an according DHCP-Server. In case that this is not available, please install the supplied USB-Driver-Package to your computer and connect it to the Mini-USB port of the integrated data logger/modem.

4 Operation

HailSens devices are delivered pre-wired. For [external cable connection](#) see the chapter with the same name.

HailSens IoT is designed for unattended use. Once properly installed, powered-up and configured, the sensor unit operates on its own and does not require any specific user-interaction.

4.1 HailSens IoT: Electronics

The HailSens Series II electronics are contained in a greyish box mounted on the support arm right beneath the transducer plate. The box contains all electronics parts required for the operation of the sensor. In normal circumstances, the box does not need to be opened: all signals are accessible via connectors on the outside of the box.

4.2 HailSens IoT: Power Supply

Nominal supply voltage is 12 VDC. For the entire voltage range see the Data Sheet.

The sensor is delivered without a power supply. Potential power supplies are:

- 12V/ 1 Amp DC power supplies,
- solar power unit with battery and battery charger.

The sensor is powered via the 4-pin connector on the electronic box.

PIN	Colour	Assignment
1	Brown	+12VDC
2	White	N/A
3	Black	GND
4	Blue	N/A

Table 1 - PIN-Out M12 4-Pin Power Connector

4.3 RESTful API/JSON

The HailSens IoT is programmed to transmit datagrams in JSON (JavaScript Object Notation) containers to a RESTful API server. JSON is a minimal, readable format for structuring data.

- Datasphere users: API and data formats are of no particular interest for users whose HailSens device(s) is (are) reporting directly to KISTERS datasphere (optional Cloud-based data management).
- For users who wish to develop their own IP endpoint, a separate document of technical information for programmers is available on request.

5 Maintenance

The entire design of the HailSens IoT has been with an eye on limiting maintenance efforts.

- The transducer plate is tilted by 10°. This ensures that rain washes debris from the plate.
- The powder-coated sensor body is weather resistant.
- Inlets and outlets are through standard connectors. If properly used, no room is left for insects to intrude into the sensor body.
- The unit does not need any consumables and has no moving mechanical parts.

5.1 Overall Visual Check

During site visits check the sensor for mechanical damage.

Check whether all cables are properly connected and that no mechanical strain is exerted on cables, leads or wires.

The sensor electronics box is equipped with an earth stud. Check whether the stud is properly connected to an earth pike or to an electrically conductive part of the mounting pole.

Visually inspect the transducer plate for visible cracks or rifts. Visible cracks or rifts – even if they are clearly inside the plate – will impact the measurement. The transducer unit must be replaced. Spare parts can be ordered separately:

- HailSens Transducer - Spare Part. Article Number: MON11_SMATRSCHSTRDCR

5.2 General Cleaning

Cleaning is only required when systems are either installed in polluted or dusty environments. Cleanse the system when clear marks of dirt are seen.

Thoroughly pre-rinse with warm water to loosen and wash away surface material, grit and grime.

Using a moist non-abrasive sponge, gently wash with a mild diluted soap or detergent.

Rinse thoroughly with lukewarm clean water. To prevent water spots, thoroughly dry the glazing with a dry soft cloth.

5.2.1 Do's and Don'ts

- Do not use abrasive cleaners.
- Do not use high alkaline cleaners (high pH or ammoniated).
- Do not leave cleaners sitting on polycarbonate (transducer plate) for periods of time; wash off immediately.
- Do not apply cleaners under direct sunlight or at elevated temperatures.
- Do not clean the polycarbonate transducer plate with any unapproved cleaners. When in doubt, seek guidance.
- Using scrapers, squeegees, razors or other sharp instruments may permanently scratch the polycarbonate transducer plate.

6 Troubleshooting

In case the sensor does not work as expected, please contact the distributor or the manufacturer.

7 Repair

KISTERS precision instruments and data loggers are produced in quality-controlled processes. All KISTERS production and assembly sites in Australia, New Zealand and Europe are ISO 90001 certified. All equipment is factory tested and/or factory calibrated before it is shipped to the client. This ensures that KISTERS products perform to their fullest capacity when delivered.

Despite KISTERS most rigorous quality assurance (QA), malfunction may occur within or outside of the warranty period. In rare cases, a product may not be delivered in accordance with your order.

In such cases KISTERS' return and repair policy applies. For you as a customer, this means the following:

- Contact KISTERS using the Repair Request Form and the Declaration of Contamination made available online:

Region (Language)	Download Link
Asia-Pacific (English)	Repair Request Form (APAC) Declaration of Contamination (APAC)
Europe, the Middle East and Africa (English)	Repair Request Form (EMEA) Declaration of Contamination (EMEA)
Germany (German)	Repair Request Form (DE) Declaration of Contamination (DE)

In response you will receive a reference number that must be referenced on all further correspondence and on the freight documents accompanying your return shipment.

- Please provide as much information and/or clear instructions within the return paperwork. This will assist our test engineers with their diagnosis.
- Please do not ship the goods prior to obtaining the reference number. KISTERS will not reject any equipment that arrives without reference number; however, it may take us longer to process.

Custom requirements for items sent to KISTERS for warranty or non-warranty repairs: Check with your national customs/tax authorities for details, processes and paperwork regarding tax exempt return of products. Typically, special custom tariff codes are available (such as HS Code = 9802.00) that verify the item is being returned for repair and has no commercial value. Please note that the customs invoice / dispatch documents should also clearly state: "Goods being returned to manufacturer for repair - No Commercial value". It is mandatory to have any returned goods accompanied by a commercial invoice on headed paper. KISTERS reserves the right to charge the customer for time spent rectifying incorrect customs documents.

Note: Please ensure that your goods are packed carefully and securely. Damage that occurs during transit is not covered by our warranty and may be chargeable.

8 Technical Data

Measured Parameter(s)	kinetic energy [J] Derived pellet equivalent diameter [mm]
Range	0,005 J ... 28 J Lower detection level: ≥ 5 mm (hail pellets according to WMO)
Accuracy	kinetic energy and pellet equivalent diameter: ± 10 % (according specific mass density on ice and spherical model)
Data Transmission	Physical output: <ul style="list-style-type: none"> ▪ wireless IP data modem, SMA connector, antenna ▪ wired: Ethernet RJ45 connector JSON datagrams via LTE-M (4G) or Ethernet to defined RESTful web service JSON: timestamp, pellet kinetic energy, pellet equivalent diameter, calibration factor Heartbeat: user-configurable, default: every 6h Measurement data: 1 data package per impact
Local Communication	Micro-USB
Housing	Aluminium die-cast, IP66
Supply Power	nominal: 12 VDC - Range: 10...18 VDC
Power Consumption	60 mA at 12 VDC (~ 0.7 W), wireless comms engaged max 120 mA at 12 V (1.4 W)
Operating Temperature	Deployment operating and storage temperature: -40 °C to $+70$ °C Calibrated measurement range: 0 to $+70$ °C Humidity: 0 - 100 % RH
Ingress Protection	IP66
Dimensions	<ul style="list-style-type: none"> ▪ Transducer plate (round): \varnothing 500 mm (19.685") ▪ Mounting: 2" to 4" pole on a heavy concrete ground plate: (500 x 500 x 50) mm (L x B x H) Height: 300 mm
Weight	6 kg net

9 Obligations of the Operator and Disposal

When disposing of the units and their accessories, the applicable local regulations regarding environment, disposal and occupational safety must be observed.

Before dismantling

- Electrical Devices:
 - Switch off the units.
 - Disconnect electrical appliances from the power supply, regardless of whether the appliances are connected to the mains or to another power source.
- Mechanical devices:
 - Fix all loose components. Prevent the device from moving independently or unintentionally.
 - Loosen mechanical fastenings: Please note that appliances can be heavy and that loosening the fastenings may cause them to become mechanically unstable.

Disposal

Operators of old appliances must recycle them separately from unsorted municipal waste. This applies in particular to electrical waste and old electronic equipment.

Electrical waste and electronic equipment must not be disposed of as household waste!

Instead, these old appliances must be collected separately and disposed of via the local collection and return systems.

Integrated or provided batteries and accumulators must be separated from the appliances and disposed of at the designated collection point. At the end of its service life, the lithium-ion battery must be disposed of according to legal provisions.

EU WEEE Directive

















As players in the environmental market, KISTERS AG is committed to supporting efforts to avoid and recycle waste. Please consider:

- Avoidance before recycling!
- Recycling before disposal!



This symbol  indicates that the scrapping of the unit must be carried out in accordance with Directive 2012/19/EU. Please observe the local implementation of the directive and any accompanying or supplementary laws and regulations.

Contact Data

Europe	KISTERS Europe	 +49 2408 9385 0
		 hydromet.sales@kisters.eu
		 www.kisters.eu
Australia	KISTERS Australia	 +612 9601 2022
		 sales@kisters.com.au
		 www.kisters.com.au
New Zealand	KISTERS New Zealand	 +64 7 857 0810
		 sales@kisters.co.nz
		 www.kisters.co.nz
Latin America	KISTERS Latin America	 +57 350 575 4079
		 sales@kisters-latam.com
		 www.kisters-latam.com
North America	KISTERS North America	 +1 561 459 4876
		 kna@kisters.net
		 www.kisters.net
Spain	KISTERS Ibérica	 info@kisters.es
		 www.kisters.es

